

MASTEIA

by Mattea Zorzenoni

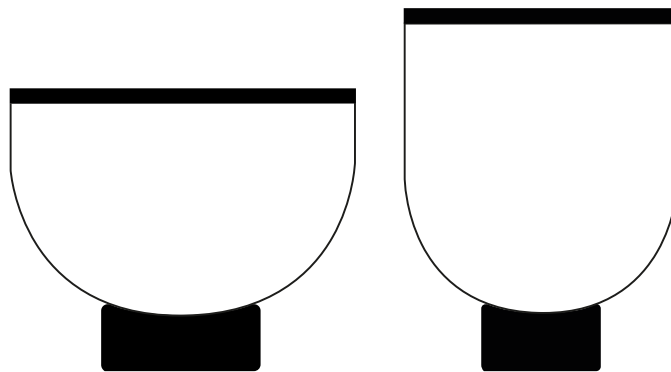

Erano gli anni '70 quando abbiamo cominciato a sperimentare con il vetro di Murano e, anche se le generazioni sono cambiate, il vetro si soffia come una volta: ci vogliono un maestro vetraio e due polmoni forti. Lavorare al giorno d'oggi con questo materiale è come rivisitare un piatto della tradizione. Gli ingredienti rimangono gli stessi, ma nel sapore trovi qualcosa di nuovo.

We started to experiment with Murano glass in the 1970s and, even if the generations have changed, the glass is blown as it once was: it needs a master glassblower and two strong lungs. Working with this material every day is like revisiting a traditional dish. The ingredients are the same but there is something new in the taste.

DIMENSIONI | DIMENSIONS



lunghezza | width: 49,6 cm
larghezza | depth: 49,6 cm
altezza | height: 42,3 cm

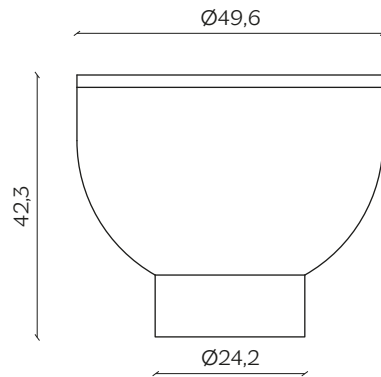

lunghezza | width: 35 cm
larghezza | depth: 35 cm
altezza | height: 52,8 cm

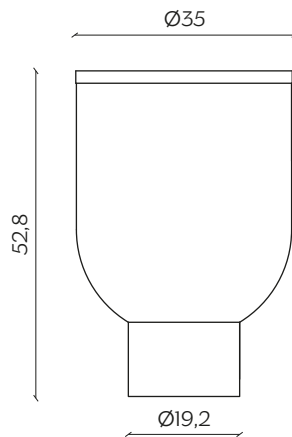

AMBIENTE | ENVIRONMENT

interno | indoor

DOWNLOAD | DOWNLOADS

la guida Cura e Manutenzione è disponibile su miniforms.com
Care and Maintenance guide is available at miniforms.com

file 2D, 3D e fotografie sono disponibili su miniforms.com
2D, 3D files and hi-res images are available at miniforms.com

FINITURE | FINISHES

VETRO | GLASS

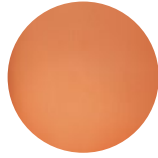

Vetro Soffiato
Ambra
Amber Blown
Class

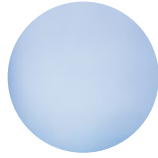

Vetro Soffiato
Blu
Blue Gray Blown
Class

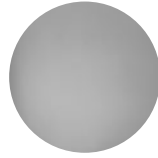

Vetro Soffiato
Grigio
Smoked Gray
Blown Class

BASE E PIANO | BASE AND TOP

Legno | Wood



Frassino
Ash



Frassino Nero
Black Ash



Frassino
Antracite
Anthracite Ash



Noce Canaletto
Canaletto
Walnut