



PHOLC EDITION 2021

The Pholc vision begins with classic Scandinavian design sensibilities; blending historical references with contemporary touchpoints for a new take on modern lighting. A melting pot of the unique and the regular, of materials and detailing; where bold design means exceptional quality and aesthetics have longevity and relevance.

Pholc curates and collaborates with talented designers whose work carries a clarity of expression. Individuals who have the courage and skill to create unique statements, and care deeply for the details. They design for the future. And together we encounter new trajectories for Pholc and for living.



INTRODUCING ROMB

A few Rombs can be used at alternating angles, like yachts in a regatta, passing each other as they turn around a buoy. It's often easy to take lamps as singular pieces but the beauty really emerges when you use many of them at the same time.

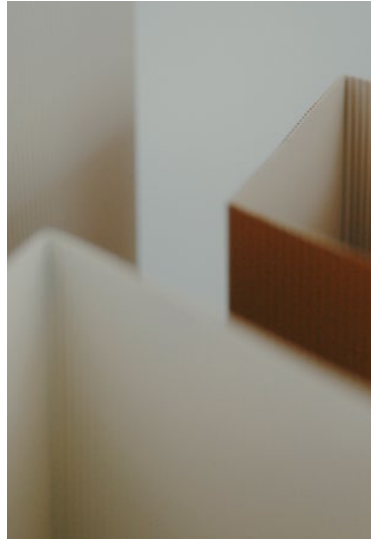

ROMB



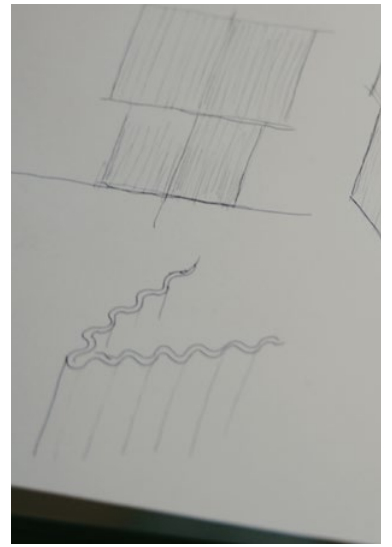

“Romb is a lamp that’s quiet, discreet and warm.
Enough to set a tone but not dictate it.”

—MATS BROBERG AND JOHAN RIDDERSTRÅLE



ROMB IS A LIGHT WHICH PLAYS TRICKS ON PERCEPTIONS OF FORM. Designed by Broberg & Ridderstråle, the lamp's unique rhombus shape developed organically from a process the duo uses when working on architecture projects.

“We often use corrugated cardboard when modeling potential designs for buildings. It adds a little texture to a model roof. As we were forming it one day, the architecture prototypes began to take shape as a design piece, which eventually formed the foundation for Romb,” recalls Johan Ridderstråle.

Sensing that the emerging rhombus shape might be interesting as a lamp, the designers reached out to Maja Norburg, Pholc's founder, and explained the central idea. Romb would be a relatively neutral lamp, which slowly draws you in with increasing layers of subtle detailing.

Pholc's brand journey has been one that's developed almost symbiotically with its collaborators. Each project helps to enrich its DNA with new expressions and ways to work with lighting. In the case of Romb, the collaboration explores Pholc's desire to **CREATE AGELESS PIECES NOT TIED TO A SPECIFIC PLACE AND TIME**, but always feeling relevant wherever they are used. The subtle detailing which has emerged, and relative neutrality in terms of colour, make it a piece you're unlikely to ever part with.

The lamp's shade is a compressed rhombus shape that is split into two forms; one larger than the other, which cast an interesting direct light upwards but also indirectly downwards, onto the base. When viewed straight-on, the lamp appears to have a commanding presence, yet is narrow enough that **IT CAN OCCUPY A POSITION ON THIN SURFACES LIKE WINDOWSILLS.**

“We scaled down the corrugations so that they're now more decorative. For this, we developed **A CUSTOM RIPPLED ALUMINIUM** which is sheer on the inside of the shade but catches light in a really interesting way on the outside. It's seamlessly welded to enhance the shape and powder-coated so it bounces light softly,” continues Ridderstråle.

One of the elements the designers were keen to resolve is that the light should possess **A DECORATIVE PRESENCE WHEN IT'S NOT IN USE.** The colours used for the shade change softly during different times of the day, and the lamp demonstrates Broberg & Ridderstråle's signature balance between form and artistic expression.

Romb is available in two sizes, each of which displays the versatile 'larger than life' character. The shade is offered in Cotton and Cumin, with a dimmable light source. The designers are quick to point out that both colourways and sizes have been considered carefully, to free up how Romb can be placed in a space; “Romb is a lamp that's quiet, discreet and warm. Enough to set a tone but not dictate it.”

PAGE 3
ROMB 48 TABLE
ITEM NO° 217 318 CUMIN

THIS SPREAD
MATS BROBERG AND JOHAN RIDDERSTRÅLE
DISCUSS THEIR INSPIRATION BEHIND ROMB.







LEFT
ROMB 48 TABLE
ITEM NO° 217 318 CUMIN
ROMB 36 TABLE
ITEM NO° 207 318 CUMIN

ABOVE
ROMB 48 TABLE
ITEM NO° 217 313 COTTON

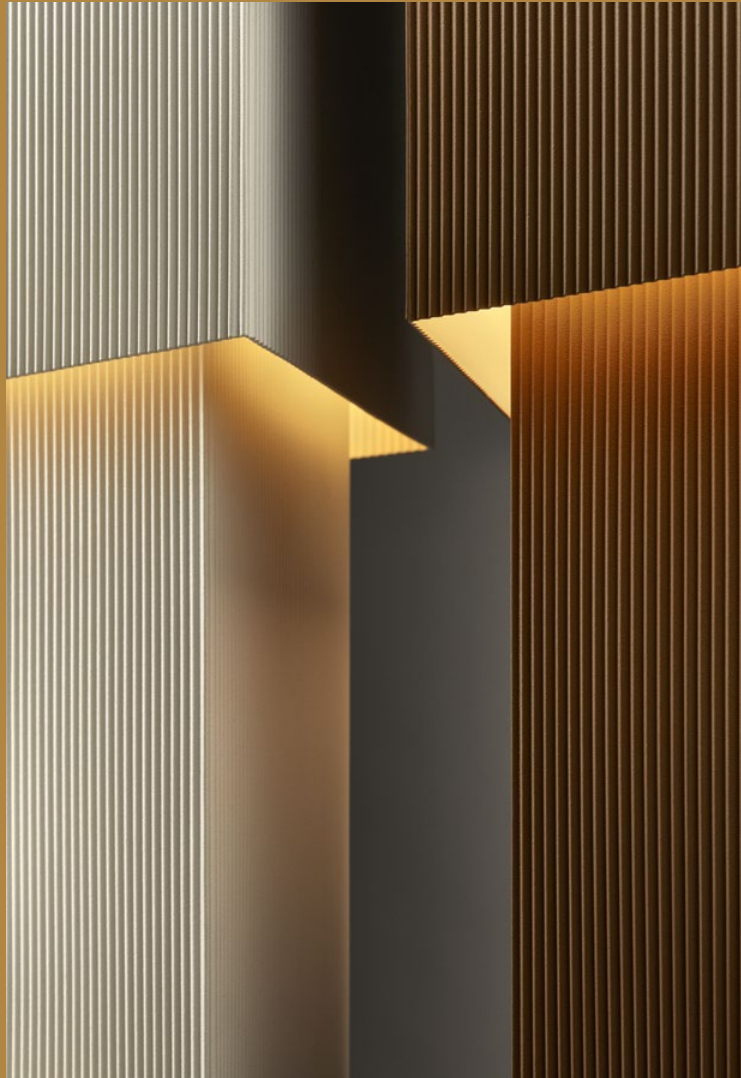

With a composition that alludes to mass and weight, Apollo is a lamp made from a solid piece of machine-turned brass or aluminium. Its conical shapes balance end-on-end like spinning gyros, emphasising a dynamic, downward, thrusting force. A lamp with a heightened material presence, with its surfaces left deliberately raw. The Apollo family comes in a range of colours that can be used singularly or hanging in various heights as a group constellation. A new addition to the family is the distinctive Apollo 180 floor lamp, in lacquered aluminium. The upward turning conical shapes give an indirect light.

BROBERG & RIDDERSTRÅLE

2018–2020



APOLLO



PREVIOUS PAGE AND ABOVE
APOLLO 59 PENDANT
ITEM NO° 592 114 ALUMINIUM

RIGHT
APOLLO 180 FLOOR
ITEM NO° 792 414 ALUMINIUM



The Donna pendant lamp projects the feeling of a soft pleated textile, although it's actually made from thin, light aluminium. Its form is inspired by the chic fabrics used in high fashion and the challenges of creating this softness using a hard material instead of a textile. A beautiful and versatile piece with an expressive personality; equally at home in all environments. For larger spaces, the Donna Line and Donna Circle can be selected in four, six or eight lamp variants, casting a warm direct light downwards.

STINA SANDWALL & NINA JOBS

2019-2020



DONNA



LEFT
DONNA CIRCLE 100 PENDANT
ITEM NO° 964 185 BLACK INK

ABOVE
DONNA 18 PENDANT
ITEM NO° 961 113 LINEN

FOLLOWING SPREAD
DONNA CIRCLE 100 PENDANT
ITEM NO° 964 185 BLACK INK









LEFT
DONNA CIRCLE 60 PENDANT
ITEM NO° 963 163 LINEN

ABOVE
DONNA LINE 120 PENDANT
ITEM NO° 962 144 BLUSH



ABOVE
DONNA 7 PENDANT
ITEM NO° 960 118 AUTUMN LEAVES

The Kandinsky pendant lamp is inspired by the abstract circle paintings from the artist of the same name, created during his time at the Bauhaus school in the 1920s. A sphere and a spear play the main characters in the lamp's composition, piercing each other in mid-air. The delicate balance of the two elements evokes a dramatic sensation of weightlessness and precision but also fragility. The custom-made light source is shaped and fitted seamlessly as part of the glass sphere. Emitting its glow from the middle of the hand-blown smoked glass, the lamp is dimmable to set the mood of a space. Kandinsky is available in two sizes, with a 300 or 450mm wide glass sphere. It hangs powerfully on its own, above a table or feature design element, or as a group, to cast its soft, diffused light over a larger space.

BROBERG & RIDDERSTRÅLE

2019

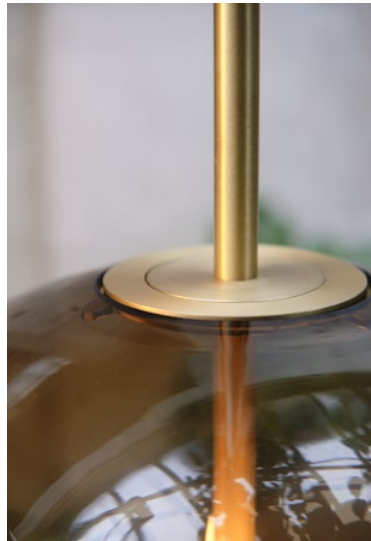

KANDINSKY



ABOVE AND RIGHT
KANDINSKY 45 PENDANT
ITEM NO° 518 112 SMOKED BROWN—BRASS



“Give me a lamp that will look great in a New York loft.” With those words, a new collection was born. Using black metal tubes and a glass sphere was a given; just think of the typical New York balcony rails and the rounded streetlights on Brooklyn Bridge. Working with these ingredients resulted in a ceiling lamp where four equal parts are linked together. The construction resembles a mobile when the elements are turned, so giving this unique lamp its name.

MONIKA MULDER

2016



MOBIL



LEFT
MOBIL 70 PENDANT
ITEM NO° 510 138 BRUSHED BRASS

ABOVE
MOBIL TABLE
ITEM NO° 510 315 MATTE BLACK
MOBIL 70 PENDANT
ITEM NO° 510 138 BRUSHED BRASS

FOLLOWING PAGE
MOBIL 100 PENDANT
ITEM NO° 510 155 MATTE BLACK



FACING

Introducing the curious couple behind Pholc

THE

FUTURE



(1)



(2)

(3)



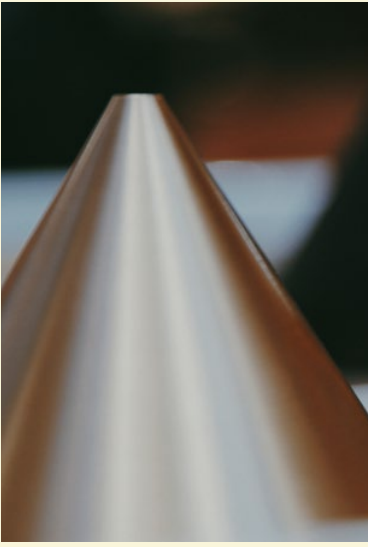

(4)

MEET MAJA AND SAMUEL NORBURG: partners in life and work – and guardians of the quietly exacting philosophy behind Pholc. Leading a modest and nimble team, Maja heads up the creative studio while Samuel oversees the company’s operations. The couple agrees that when it comes to making lamps, their individual dreams have connected perfectly.

With their entrepreneurial backgrounds and a history of manufacturing architectural hardware on Samuel’s side of the family, the couple had always nurtured ambitions of building their own company and channelling their energies into developing a beautiful and singular product.

Pholc launched in 2015, a small and sprightly challenger to the comfortably established and frequently sombre lighting brands then enjoying ubiquity. 2017 brought the studio early acclaim in the form of the Elle Decoration Swedish Design Award for Best Lamp. A significant milestone, the prize celebrated Pholc’s intentions and helped the brand to earn trust among new followers.

Maja is quick to point out that **PHOLC IS NOT SIMPLY A SCANDINAVIAN DESIGN BRAND, BUT A DISTINCTIVELY SWEDISH ONE.** In the past, the Nordic region’s creative scene has been dominated by the Danish design narrative. But now, major global players like Spotify and Acne, and smaller names like Pholc, are changing the story.

SO WHAT DOES IT MEAN TO BE A SWEDISH BRAND? ‘We define it in our own way,’ says Maja. **FOR PHOLC, IT’S ABOUT CONSTANTLY LOOKING FORWARD.** One of the brand’s core concerns is to be – and feel – informed. It’s a daily mission for Pholc’s founders and their close circle of collaborators and partners; a way of viewing and interrogating the world.

Establishing a reputation in Sweden and replicating that success across Europe requires building up a reserve of self-confidence, however lightly worn. It’s **A SUBTLE ASSURANCE THAT STEMS FROM REMAINING OPEN AND CURIOUS, WHILE ALWAYS SCRUTINISING THE NATURE AND DEPTH OF QUALITY.** Maja and Samuel understand that meaningful design is about much more than the surface may suggest. It’s what’s on the inside that counts; the thinking and care that has gone into the making. Trust in Pholc’s products is only won through a rigorous commitment to long-lasting quality.

Where adjacent design brands often tend to look backwards, **PHOLC DARES TO PEER AHEAD, NAVIGATING THE SOCIETAL CURRENTS THAT PROPEL THE WORLD FORWARD CREATIVELY.** To stay in touch with the latest direction of travel, Maja and Samuel choose their collaborators according to strict criteria. Evidence of a natural chemistry between brand and designer is critical. Every partner must enter into an agreement to uphold Pholc’s values of remaining **EXPRESSIVE, RELEVANT, SOPHISTICATED AND INFORMED** – whatever the product or mood of the season. Often youthful, and unconstrained by historic design precedents, **PHOLC’S COLLABORATORS ARE A FORCE OF ENERGETIC TALENT AND UNRELENTING CURIOSITY.** Egos must be left at the door. Pholc is a supportive environment in which to express a fresh vision – centred around the brand’s unchanging values and the customer they lovingly imagine as the starting point for every brief.

(1 – 4)
**MAJA AND SAMUEL VISIT NOTE
DESIGN STUDIO TO COLLABORATE ON
PRODUCT DEVELOPMENT. MATERIALITY
IS AN IMPORTANT PART OF THE
CONVERSATION.**



(5)

(5)
APOLLO 59 PENDANTS GRACE THE INTERIORS OF DOUGLAS HOUSE, A DEVELOPMENT BY THE OFFICE GROUP IN LONDON. DESIGN BY NOTE DESIGN STUDIO.

(6)
THE OFFICE GROUP'S SUMMIT HOUSE IN LONDON FEATURES SPACES CONCEIVED BY NOTE DESIGN STUDIO. HERE THE KANDINSKY PENDANT 45 MAKES AN APPEARANCE.

(7)
BOUNCE HAS A YOUTHFUL, ENERGETIC CHARACTER. HERE'S IT'S AN EYE-CATCHING ADDITION TO THE COUNTER AT SULT IN COPENHAGEN.



(7)

(6)



Beyond their roster of designers including Broberg & Ridderstråle, Moniker Mulder, Stina Sandwall and Nina Jobs, Pholc partners with Stockholm-based design studio Note to establish a rich and robust creative foundation upon which the brand and its collaborators can build. Bringing new perspectives and disciplines from outside the lighting industry, a partner like Note Design Studio further opens up the conversation that fuels the brand's long-term output – from tangibles like catalogues and product briefs, to distilling and evolving the brand's ethos and attitude.

IN THE PHOLC ATELIER, IDEAS ARE GIVEN AMPLE TIME TO FORM AND EVOLVE, AND COLLABORATION IS STRENGTHENED BY CONSTANT DIALOGUE. Before any detailed drawings are produced, the right feeling – a strong mood, an irresistible story – must first be established. That feeling should translate the values of Pholc in new and unexpected ways. Designers should be willing to discard the old, instead drawing energy from asking questions and instinctively changing direction.

THE PHOLC CUSTOMER, Maja says, IS SOMEONE WHO BUYS WITH THEIR HEART. Pholc is proud to be a new brand on the scene, relishing its freedom to move quickly and effortlessly from one inspiration to the next. Maja and Samuel believe that although their customers may possess a sweeping knowledge of design history, it's the future of objects that most excites them. **PHOLC LAMPS ARE PURCHASED WITH FEELING AND COME TO LIFE IN WELL-LOVED HOMES.** 'We want to elevate the room,' Samuel explains. A Pholc lamp is an expression of its maker's personality, a laid-back sophistication that feels at home in a range of environments. Indeed, the Swedish instinct for minimalism lends Pholc products a chameleonic quality that embraces a diversity of tastes and attitudes to living.

Pholc is keen to sidestep the masculine mood that can govern much of the lighting world. Their openness to new modes of thinking and creating means that a Pholc lamp stands out and feels relevant to the present moment, yet also timeless, manifested in its sensitive and long-lasting craftsmanship. An attitude of openness also extends to their customer base. Maja and Samuel believe firmly in promoting inclusivity in the design industry, welcoming the many, rather than the few. 'We are not a club.' It's a distinctly international point of view that reflects a rich cultural diet and a hunger for change. There is plenty of freedom to roam inside the Pholc guidelines. The words expressive, sophisticated, relevant and informed balance each other out. One value cannot be pursued at the cost of another. **THERE IS AN ART TO FINDING ONE'S PLACE IN THE UNFAMILIAR.**

(8)
THE BLEND PENDANT IS A GEOMETRIC STATEMENT.

(9)
A FRIENDLY WAVE FROM THE HANS TABLE.

(10)
THE APOLLO 59 PENDANT BRINGS A CHEERFUL ACCENT IN DEEP SEA.

(11)
AT HOME WITH COPENHAGEN-BASED ART DIRECTOR AND PHOTOGRAPHER STAFFAN SUNDSTRÖM AND HIS MOBIL 100 PENDANT.



(8)



(9)



(10)

(11)



“Running your own company is a lifestyle.
You use all the fire you have to create something that feels authentic.”

— MAJA AND SAMUEL NORBURG

PAGE	34	APOLLO 39 PENDANT		
PAGE	35	APOLLO 59 PENDANT (GU10)		
PAGE	36	APOLLO 59 PENDANT		
PAGE	37	APOLLO 79 PENDANT		
PAGE	38	APOLLO 180 FLOOR		
PAGE			39	BELLMAN WALL
PAGE				
PAGE				40 BLEND PENDANT
PAGE				41 BLEND CEILING
PAGE				42 BLEND FLOOR
PAGE	43	BOUNCE 116 PENDANT		
PAGE	44	BOUNCE 169 PENDANT		
PAGE		45 CHAMPAGNE PENDANT		
PAGE		46 CHAMPAGNE TABLE		
PAGE			47	DONNA 7 PENDANT
PAGE			48	DONNA 18 PENDANT
PAGE			49	DONNA CIRCLE 60 PENDANT
PAGE			50	DONNA CIRCLE 100 PENDANT
PAGE			51	DONNA LINE 120 PENDANT
PAGE	52	EDGE 20 PENDANT		
PAGE				53 HANS 35 PENDANT
PAGE				54 HANS 50 PENDANT
PAGE				55 HANS 35 TABLE
PAGE				56 HANS 50 FLOOR
PAGE		57 KANDINSKY 30 PENDANT		
PAGE		58 KANDINSKY 45 PENDANT		
PAGE			59	MOBIL 70 PENDANT
PAGE			60	MOBIL 100 PENDANT
PAGE			61	MOBIL TABLE
PAGE			62	MOBIL 12 WALL
PAGE			63	MOBIL 46 WALL
PAGE			64	MOBIL 46 WALL (FIXED)
PAGE			65	MOBIL 150 WALL
PAGE	66	PEARLS 65 PENDANT		
PAGE	67	PEARLS 80 PENDANT		
PAGE				68 ROMB 36 TABLE
PAGE				69 ROMB 48 TABLE
PAGE		70 SPINN 39 PENDANT		
PAGE		71 SPINN 39 FLOOR		

APOLLO 39 PENDANT

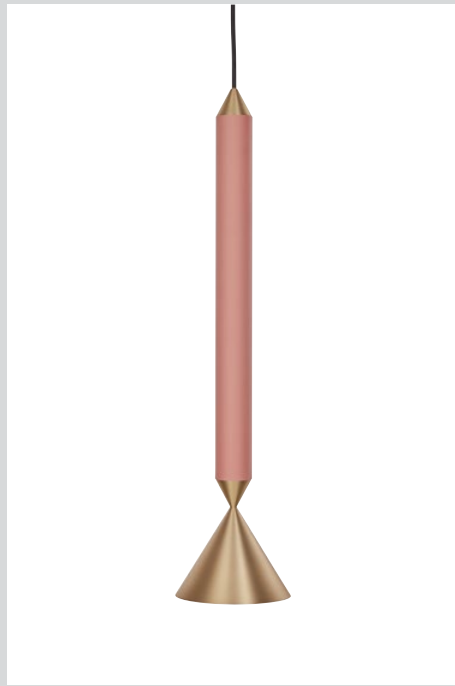

ITEM NO° 392 114
CORAL PINK—POLISHED BRASS



ITEM NO° 392 111
BLACK INK—
POLISHED BRASS



ITEM NO° 392 116
FOREST—
POLISHED BRASS



ITEM NO° 392 117
DEEP SEA—
POLISHED BRASS



ITEM NO° 392 118
HONEY GOLD—
POLISHED BRASS



ITEM NO° 392 119
LIGHT GREY—
POLISHED ALUMINIUM



ITEM NO° 392 113
WINTER WHITE—
POLISHED ALUMINIUM



ITEM NO° 392 115
BLACK INK—
POLISHED ALUMINIUM



ITEM NO° 392 114 AL
CORAL PINK—
POLISHED ALUMINIUM

DESIGN: BROBERG & RIDDERSTRÅLE, 2018
CATEGORY: PENDANT
MATERIAL: ALUMINIUM/BRASS & ALUMINIUM
CEILING CUP MATERIAL: PVC
SOCKET: G9
MAX WATT: 1*20W
LIGHTSOURCE: SEE RECOMMENDED LIGHTSOURCE AT PHOLC.SE
DIMMING: DEPENDING ON LIGHTSOURCE
DIFFUSER: NO
CABLE: PVC CABLE, BLACK, 300 CM
MOUNTING: CEILING CUP, BLACK, TERMINAL BLOCK
CLASS: CLASS II
IP: IP20
CERTIFICATION: CE

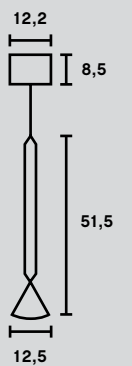

APOLLO 59 PENDANT (GU10)



ITEM NO° 592 114
ALUMINIUM

DESIGN: BROBERG & RIDDERSTRÅLE, 2018
CATEGORY: PENDANT
MATERIAL: ALUMINIUM
CEILING CUP MATERIAL: PVC
SOCKET: GU10
MAX WATT: 1*7W
LIGHTSOURCE: SEE RECOMMENDED LIGHTSOURCE AT PHOLC.SE
DIMMING: DEPENDING ON LIGHTSOURCE
DIFFUSER: NO
CABLE: PVC CABLE, BLACK, 300 CM
MOUNTING: CEILING CUP, BLACK, TERMINAL BLOCK
CLASS: CLASS II
IP: IP20
CERTIFICATION: CE

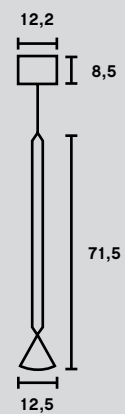

APOLLO 59 PENDANT

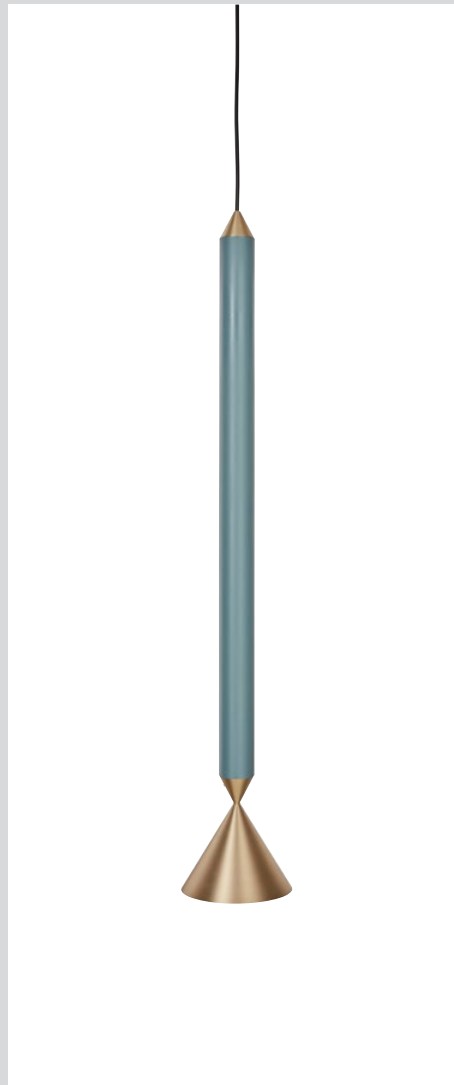

ITEM NO° 592 117
DEEP SEA—POLISHED BRASS

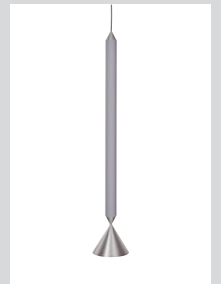

ITEM NO° 592 119
LIGHT GREY—
POLISHED ALUMINIUM

DESIGN: BROBERG & RIDDERSTRÅLE, 2018
CATEGORY: PENDANT
MATERIAL: BRASS & ALUMINIUM
CEILING CUP MATERIAL: PVC
SOCKET: G9
MAX WATT: 1*20W
LIGHTSOURCE: SEE RECOMMENDED LIGHTSOURCE AT PHOLC.SE
DIMMING: DEPENDING ON LIGHTSOURCE
DIFFUSER: NO
CABLE: PVC CABLE, BLACK, 300 CM
MOUNTING: CEILING CUP, BLACK, TERMINAL BLOCK
CLASS: CLASS II
IP: IP20
CERTIFICATION: CE



APOLLO 79 PENDANT



ITEM NO° 792 118
HONEY GOLD—POLISHED BRASS



ITEM NO° 792 115
BLACK INK—
POLISHED ALUMINIUM

DESIGN: BROBERG & RIDDERSTRÅLE, 2018
CATEGORY: PENDANT
MATERIAL: ALUMINIUM/BRASS & ALUMINIUM
CEILING CUP MATERIAL: PVC
SOCKET: G9
MAX WATT: 1*20W
LIGHTSOURCE: SEE RECOMMENDED LIGHTSOURCE AT PHOLC.SE
DIMMING: DEPENDING ON LIGHTSOURCE
DIFFUSER: NO
CABLE: PVC CABLE, BLACK, 300 CM
MOUNTING: CEILING CUP, BLACK, TERMINAL BLOCK
CLASS: CLASS II
IP: IP20
CERTIFICATION: CE

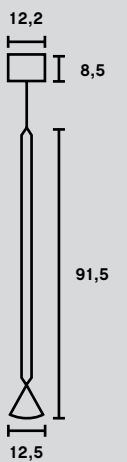

APOLLO 180 FLOOR



ITEM NO° 792 414
ALUMINIUM

DESIGN: BROBERG & RIDDERSTRÅLE, 2020
CATEGORY: FLOOR
MATERIAL: ALUMINIUM
SOCKET: GU10
MAX WATT: 1*7W
LIGHTSOURCE: SEE RECOMMENDED LIGHTSOURCE AT PHOLC.SE
DIMMING: YES
DIFFUSER: NO
CABLE: PVC CABLE, BLACK, 250 CM
MOUNTING: CABLE TYPE
CLASS: CLASS II
IP: IP20
CERTIFICATION: CE

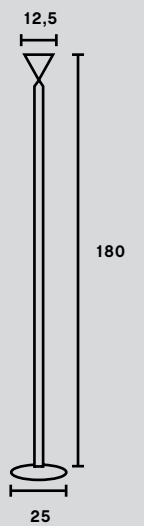

BELLMAN WALL

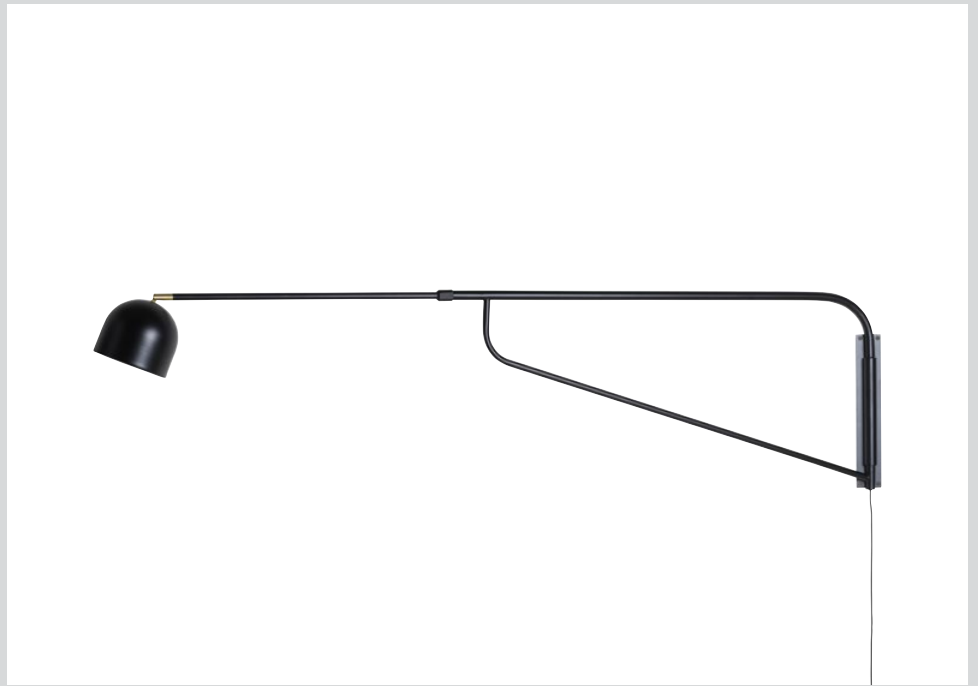

ITEM NO° 311 215
BLACK

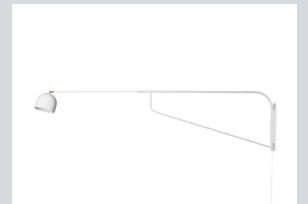

ITEM NO° 311 213
WHITE

DESIGN: SABINA GRUBBESON, 2016
CATEGORY: WALL
MATERIAL: METAL
SOCKET: E27
MAX WATT: 1*42W
LIGHTSOURCE: SEE RECOMMENDED LIGHTSOURCE AT PHOLC.SE
DIMMING: NO, ON/OFF SWITCH
DIFFUSER: NO
CABLE: PVC CABLE, MATCHING COLOUR AS SHADE, 500 CM
MOUNTING: CABLE TYPE
CLASS: CLASS II
IP: IP20
CERTIFICATION: CE

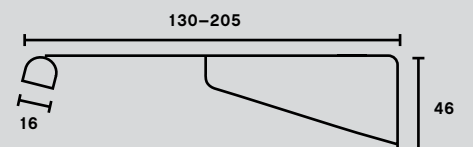

BLEND PENDANT

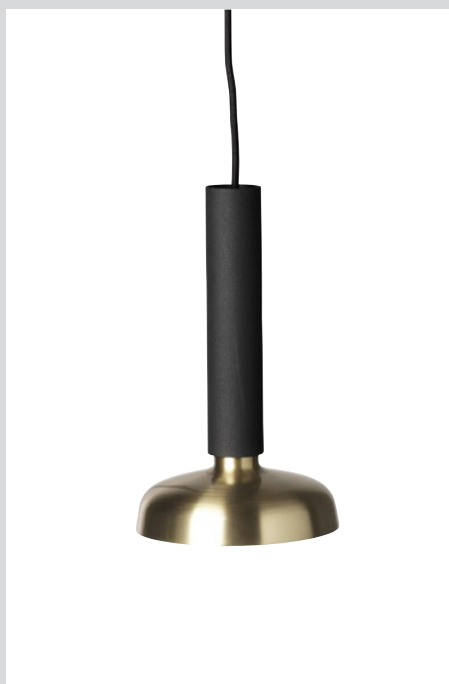

ITEM NO° 302 115
BLACK—BRASS

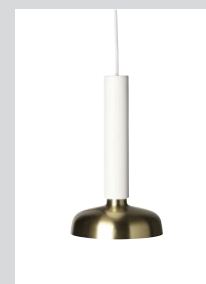

ITEM NO° 302 113
WHITE—BRASS

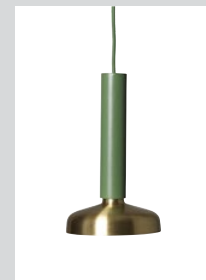

ITEM NO° 302 116
GREEN—BRASS

DESIGN: SABINA GRUBBESON, 2015
CATEGORY: PENDANT
MATERIAL: METAL & BRASS/NICKEL
CEILING CUP MATERIAL: METAL
SOCKET: G4
MAX WATT: 1*2W
LIGHTSOURCE: SEE RECOMMENDED LIGHTSOURCE AT PHOLC.SE
DIMMING: DEPENDING ON LIGHTSOURCE
DIFFUSER: NO
CABLE: TEXTILE CABLE, MATCHING COLOUR AS FRAME, 300 CM
MOUNTING: CEILING CUP, MATCHING COLOUR AS FRAME, TERMINAL BLOCK
CLASS: CLASS II
IP: IP20
CERTIFICATION: CE

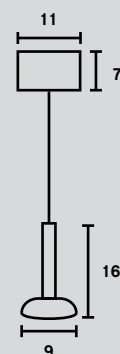

BLEND CEILING

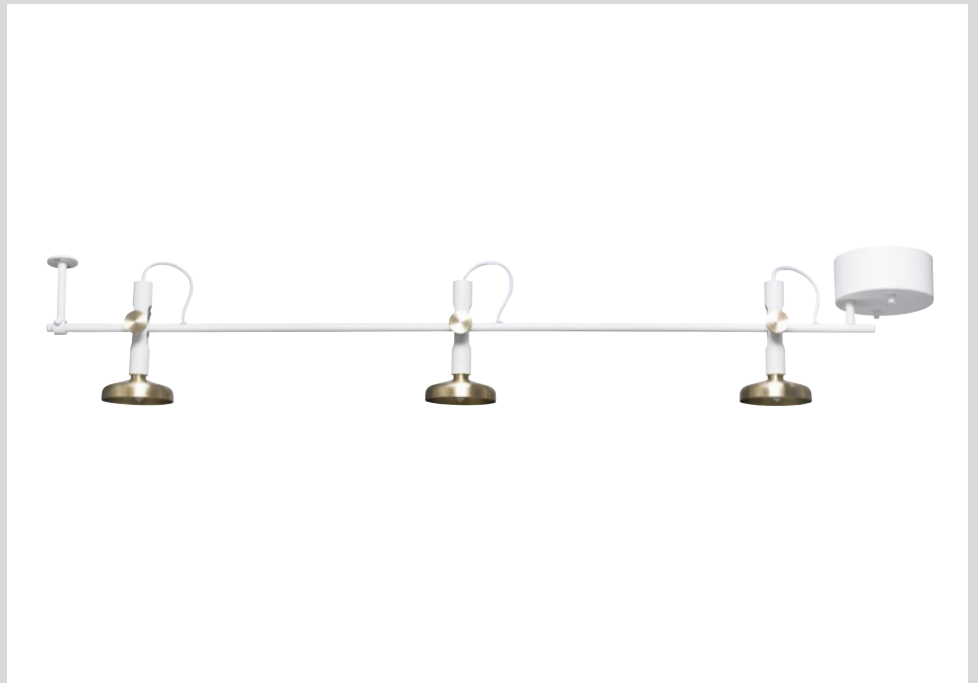

ITEM NO° 301 533
WHITE—BRASS

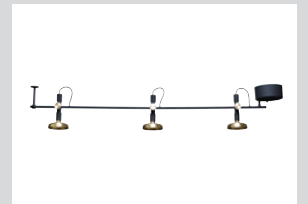

ITEM NO° 501 535
BLACK—BRASS

DESIGN: SABINA GRUBBESON, 2015
CATEGORY: CEILING
MATERIAL: METAL & BRASS
CEILING CUP MATERIAL: METAL
SOCKET: G4
MAX WATT: 3*2W
LIGHTSOURCE: SEE RECOMMENDED LIGHTSOURCE AT PHOLC.SE
DIMMING: DEPENDING ON LIGHTSOURCE
DIFFUSER: NO
CABLE: TEXTILE CABLE, MATCHING COLOUR AS FRAME
MOUNTING: CEILING CUP, MATCHING COLOUR AS FRAME, TERMINAL BLOCK
CLASS: CLASS II
IP: IP20
CERTIFICATION: CE

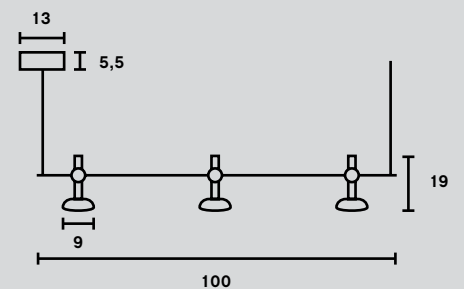

BLEND FLOOR

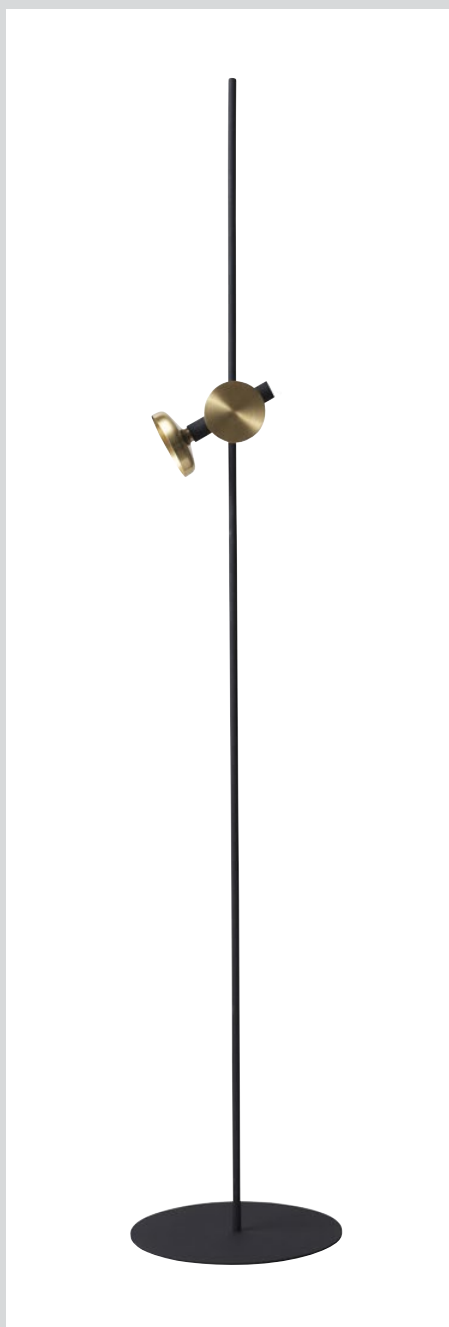

ITEM NO° 301 415
BLACK—BRASS

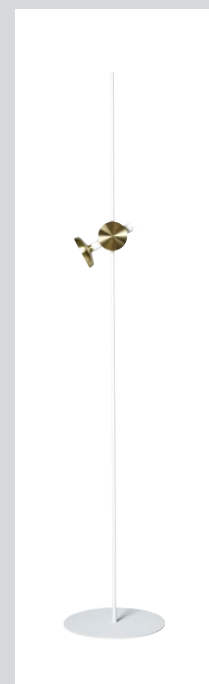

ITEM NO° 301 413
WHITE—BRASS

DESIGN: SABINA GRUBBESON, 2015
CATEGORY: FLOOR
MATERIAL: METAL & BRASS
SOCKET: G4
MAX WATT: 1*2,5W
LIGHTSOURCE: SEE RECOMMENDED LIGHTSOURCE AT PHOLC.SE
DIMMING: NO, ON/OFF SWITCH
DIFFUSER: NO
CABLE: TEXTILE CABLE, MATCHING COLOUR AS SHADE, 500 CM
MOUNTING: CABLE TYPE
CLASS: CLASS II
IP: IP20
CERTIFICATION: CE

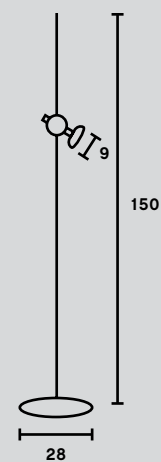

BOUNCE 116 PENDANT



ITEM NO° 514 165
MATTE BLACK

DESIGN: MONIKA MULDER, 2019
CATEGORY: PENDANT
MATERIAL: METAL & OPAL GLASS
CEILING CUP MATERIAL: METAL
SOCKET: G9
MAX WATT: 6*20W
LIGHTSOURCE: SEE RECOMMENDED LIGHTSOURCE AT PHOLC.SE
DIMMING: DEPENDING ON LIGHTSOURCE
DIFFUSER: NO
CABLE: TEXTILE CABLE, BLACK, 300 CM
MOUNTING: CEILING CUP, BLACK, TERMINAL BLOCK
CLASS: CLASS I
IP: IP20
CERTIFICATION: CE

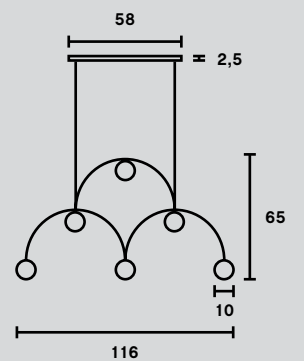

BOUNCE 169 PENDANT

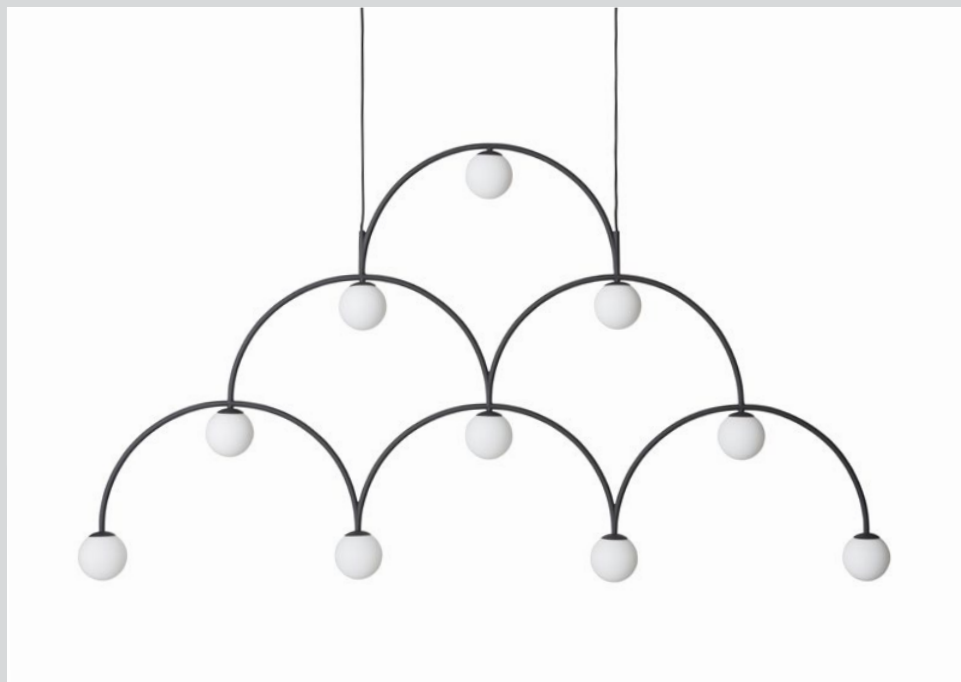

ITEM NO° 515 105
MATTE BLACK

DESIGN: MONIKA MULDER, 2016
CATEGORY: PENDANT
MATERIAL: METAL & OPAL GLASS
CEILING CUP MATERIAL: METAL
SOCKET: G9
MAX WATT: 10*20W
LIGHTSOURCE: SEE RECOMMENDED LIGHTSOURCE AT PHOLC.SE
DIMMING: DEPENDING ON LIGHTSOURCE
DIFFUSER: NO
CABLE: TEXTILE CABLE, BLACK, 300 CM
MOUNTING: CEILING CUP, BLACK, TERMINAL BLOCK
CLASS: CLASS I
IP: IP20
CERTIFICATION: CE

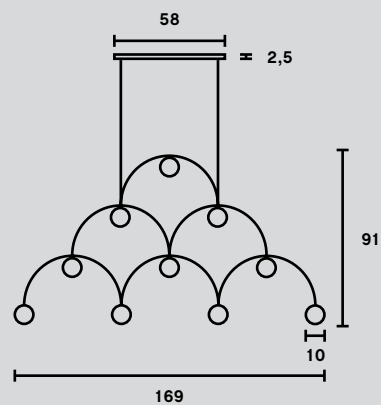

CHAMPAGNE PENDANT



ITEM NO° 202 118
SHINY GOLD FINISH



ITEM NO° 202 111
BRUSHED GOLD
FINISH



ITEM NO° 202 114
CHROME

DESIGN: MONIKA MULDER, 2016
CATEGORY: PENDANT
MATERIAL: METAL
CEILING CUP MATERIAL: METAL
SOCKET: G9
MAX WATT: 1*20W
LIGHTSOURCE: SEE RECOMMENDED LIGHTSOURCE AT PHOLC.SE
DIMMING: DEPENDING ON LIGHTSOURCE
DIFFUSER: NO
CABLE: TEXTILE CABLE, BLACK, 300 CM
MOUNTING: CEILING CUP, BLACK, TERMINAL BLOCK
CLASS: CLASS II
IP: IP20
CERTIFICATION: CE

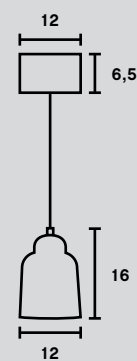

CHAMPAGNE TABLE



ITEM NO° 202 314
CHROME



ITEM NO° 202 311
BRUSHED GOLD
FINISH

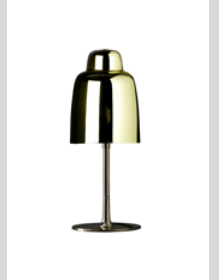

ITEM NO° 202 318
SHINY GOLD FINISH

DESIGN: MONIKA MULDER, 2016
CATEGORY: TABLE
MATERIAL: METAL
SOCKET: G9
MAX WATT: 1*20W
LIGHTSOURCE: SEE RECOMMENDED LIGHTSOURCE AT PHOLC.SE
DIMMING: DEPENDING ON LIGHTSOURCE
DIFFUSER: NO, ON/OFF SWITCH
CABLE: TEXTILE CABLE, BLACK, 300 CM
MOUNTING: CABLE TYPE
CLASS: CLASS II
IP: IP20
CERTIFICATION: CE

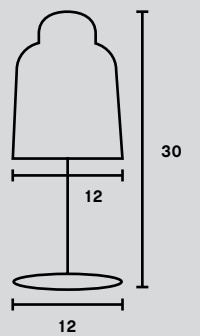

DONNA 7 PENDANT



ITEM NO° 960 114
BLUSH



ITEM NO° 960 113
LINEN



ITEM NO° 960 115
BLACK INK



ITEM NO° 960 118
AUTUMN LEAVES

DESIGN: NINA JOBS & STINA SANDWALL, 2019
CATEGORY: PENDANT
MATERIAL: ALUMINIUM
CEILING CUP MATERIAL: METAL
SOCKET: G9
MAX WATT: 1*6W
LIGHTSOURCE: SEE RECOMMENDED LIGHTSOURCE AT PHOLC.SE
DIMMING: DEPENDING ON LIGHTSOURCE
DIFFUSER: NO
CABLE: TEXTILE CABLE, MATCHING COLOUR AS SHADE, 300 CM
MOUNTING: CEILING CUP, MATCHING COLOUR AS SHADE, TERMINAL BLOCK
CLASS: CLASS II
IP: IP20
CERTIFICATION: CE

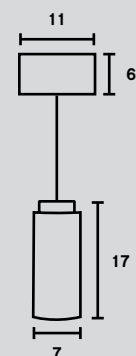

DONNA 18 PENDANT



ITEM NO° 961 118
AUTUMN LEAVES



ITEM NO°961 113
LINEN



ITEM NO° 961 114
BLUSH



ITEM NO° 961 115
BLACK INK

DESIGN: NINA JOBS & STINA SANDWALL, 2019
CATEGORY: PENDANT
MATERIAL: ALUMINIUM
CEILING CUP MATERIAL: METAL
SOCKET: E27
MAX WATT: 1*8,5W
LIGHTSOURCE: SEE RECOMMENDED LIGHTSOURCE AT PHOLC.SE
DIMMING: DEPENDING ON LIGHTSOURCE
DIFFUSER: YES
CABLE: TEXTILE CABLE, MATCHING COLOUR AS SHADE, 300 CM
MOUNTING: CEILING CUP, MATCHING COLOUR AS SHADE, TERMINAL BLOCK
CLASS: CLASS II
IP: IP20
CERTIFICATION: CE

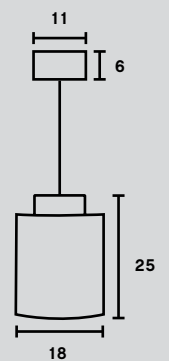

DONNA CIRCLE 60 PENDANT



ITEM NO° 963 165
BLACK INK



ITEM NO° 963 163
LINEN

DESIGN: NINA JOBS & STINA SANDWALL, 2020
CATEGORY: PENDANT
MATERIAL: ALUMINIUM
CEILING CUP MATERIAL: METAL
SOCKET: GU10
MAX WATT: 6*7W
LIGHTSOURCE: SEE RECOMMENDED LIGHTSOURCE AT PHOLC.SE
DIMMING: DEPENDING ON LIGHTSOURCE
DIFFUSER: NO
CABLE: TEXTILE CABLE, MATCHING COLOUR AS SHADE, 300 CM
MOUNTING: CEILING CUP, MATCHING COLOUR AS SHADE, TERMINAL BLOCK
CLASS: CLASS II
IP: IP20
CERTIFICATION: CE

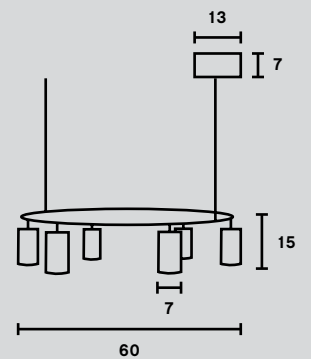

DONNA CIRCLE 100 PENDANT



ITEM NO° 964 183
LINEN



ITEM NO° 964 185
BLACK INK

DESIGN: NINA JOBS & STINA SANDWALL, 2020
CATEGORY: PENDANT
MATERIAL: ALUMINIUM
CEILING CUP MATERIAL: METAL
SOCKET: GU10
MAX WATT: 8*7W
LIGHTSOURCE: SEE RECOMMENDED LIGHTSOURCE AT PHOLC.SE
DIMMING: DEPENDING ON LIGHTSOURCE
DIFFUSER: NO
CABLE: TEXTILE CABLE, MATCHING COLOUR AS SHADE, 300 CM
MOUNTING: CEILING CUP, MATCHING COLOUR AS SHADE, TERMINAL BLOCK
CLASS: CLASS II
IP: IP20
CERTIFICATION: CE

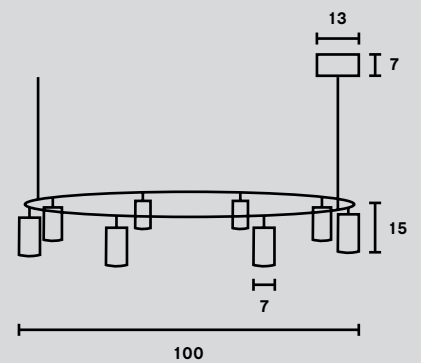

**DONNA LINE 120
PENDANT**

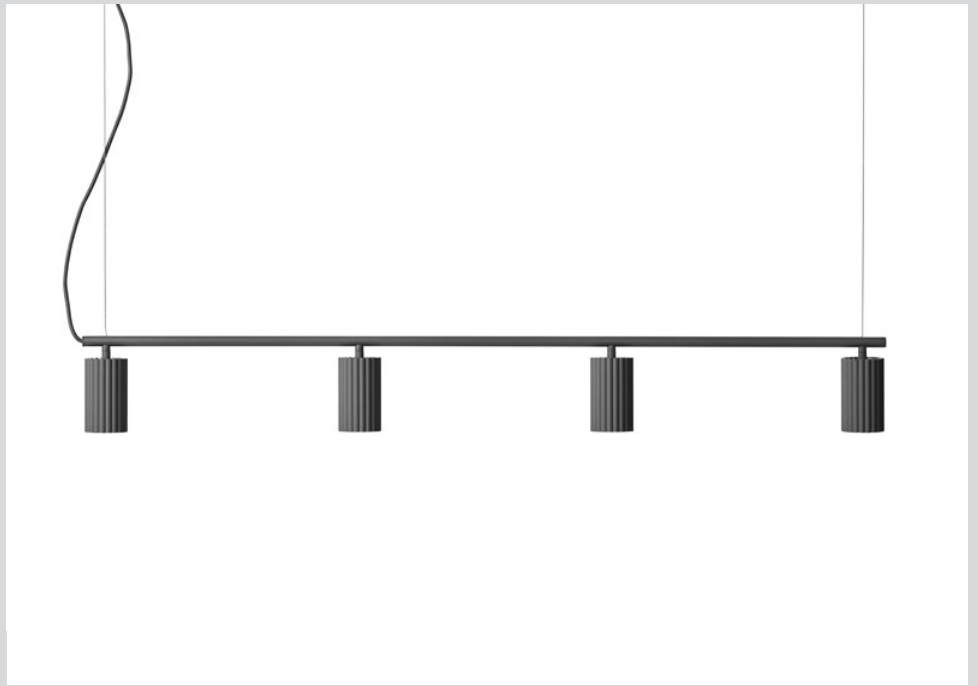

ITEM NO° 962 145
BLACK INK

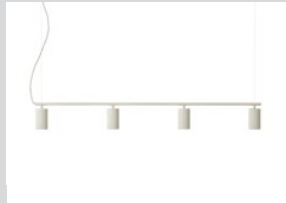

ITEM NO° 962 143
LINEN



ITEM NO° 962 144
BLUSH



ITEM NO° 962 148
AUTUMN LEAVES

DESIGN: NINA JOBS & STINA SANDWALL, 2020
 CATEGORY: PENDANT
 MATERIAL: ALUMINIUM
 CEILING CUP MATERIAL: METAL
 SOCKET: GU10
 MAX WATT: 4*7W
 LIGHTSOURCE: SEE RECOMMENDED LIGHTSOURCE AT PHOLC.SE
 DIMMING: DEPENDING ON LIGHTSOURCE
 DIFFUSER: NO
 CABLE: TEXTILE CABLE, MATCHING COLOUR AS SHADE, 300 CM
 MOUNTING: CEILING CUP, MATCHING COLOUR AS SHADE, TERMINAL BLOCK
 CLASS: CLASS II
 IP: IP20
 CERTIFICATION: CE

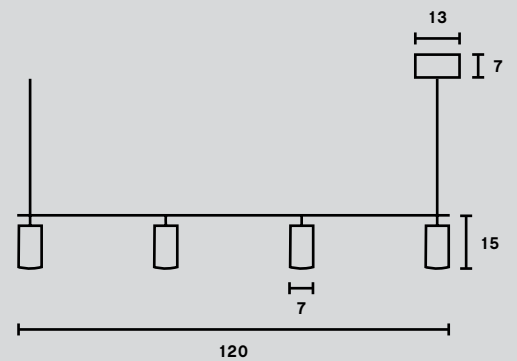

EDGE 20 PENDANT



ITEM NO° 249 116
MATTE GREEN

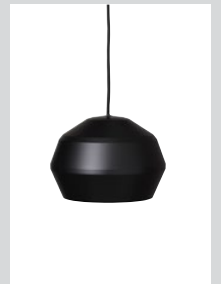

ITEM NO° 249 115
MATTE BLACK



ITEM NO° 249 119
MATTE GREY



ITEM NO° 249 113
MATTE WHITE

DESIGN: MONIKA MULDER, 2017
CATEGORY: PENDANT
MATERIAL: ALUMINIUM
CEILING CUP MATERIAL: METAL
SOCKET: E14
MAX WATT: 1*40W
LIGHTSOURCE: SEE RECOMMENDED LIGHTSOURCE AT PHOLC.SE
DIMMING: DEPENDING ON LIGHTSOURCE
DIFFUSER: NO
CABLE: TEXTILE CABLE, MATCHING COLOUR AS SHADE, 300 CM
MOUNTING: CEILING CUP, MATCHING COLOUR AS SHADE, TERMINAL BLOCK
CLASS: CLASS II
IP: IP20
CERTIFICATION: CE

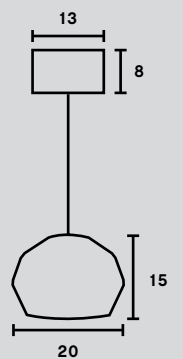

HANS 35 PENDANT



ITEM NO° 805 115
BLACK

DESIGN: MONIKA MULDER, 2015
CATEGORY: PENDANT
MATERIAL: ALUMINIUM
CEILING CUP MATERIAL: METAL
SOCKET: G9
MAX WATT: 1*20W
LIGHTSOURCE: SEE RECOMMENDED LIGHTSOURCE AT PHOLC.SE
DIMMING: DEPENDING ON LIGHTSOURCE
DIFFUSER: NO
CABLE: TEXTILE CABLE, BLACK 300 CM
MOUNTING: CEILING CUP, BLACK, TERMINAL BLOCK
CLASS: CLASS II
IP: IP20
CERTIFICATION: CE

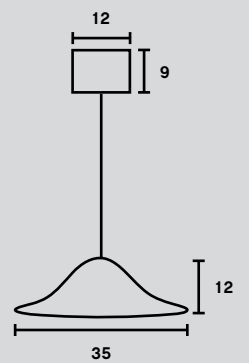

HANS 50 PENDANT



ITEM NO° 807 115
BLACK



ITEM NO° 807 113
WHITE

DESIGN: MONIKA MULDER, 2015
CATEGORY: PENDANT
MATERIAL: ALUMINIUM
CEILING CUP MATERIAL: METAL
SOCKET: E27
MAX WATT: 1*60W
LIGHTSOURCE: SEE RECOMMENDED LIGHTSOURCE AT PHOLC.SE
DIMMING: DEPENDING ON LIGHTSOURCE
DIFFUSER: NO
CABLE: TEXTILE CABLE, MATCHING COLOUR AS SHADE, 150 CM
MOUNTING: CEILING CUP, MATCHING COLOUR AS SHADE, TERMINAL BLOCK
CLASS: CLASS II
IP: IP20
CERTIFICATION: CE

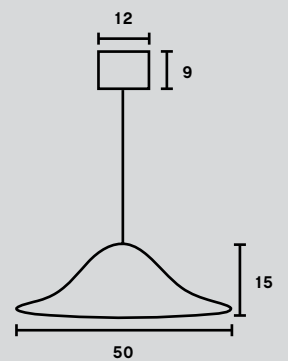

HANS 35 TABLE



ITEM NO° 805 315
BLACK

DESIGN: MONIKA MULDER, 2016
CATEGORY: TABLE
MATERIAL: ALUMINIUM
SOCKET: G9
MAX WATT: 1*20W
LIGHTSOURCE: SEE RECOMMENDED LIGHTSOURCE AT PHOLC.SE
DIMMING: NO, ON/OFF SWITCH
DIFFUSER: NO
CABLE: PVC CABLE, BLACK, 200 CM
MOUNTING: CABLE TYPE
CLASS: CLASS II
IP: IP20
CERTIFICATION: CE

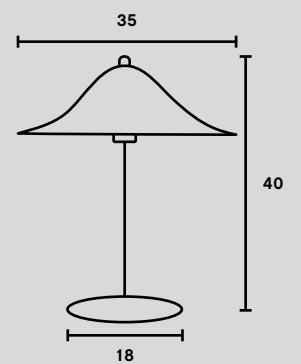

HANS 50 FLOOR

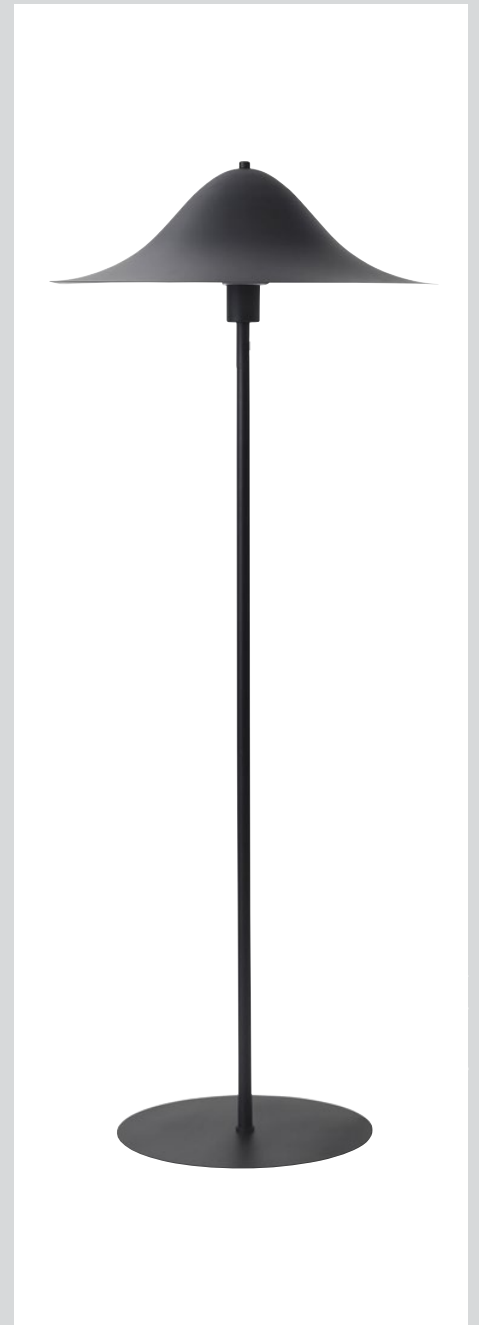

ITEM NO° 807 415
BLACK

DESIGN: MONIKA MULDER, 2015
CATEGORY: FLOOR
MATERIAL: ALUMINIUM
SOCKET: G9
MAX WATT: 1*60W
LIGHTSOURCE: SEE RECOMMENDED LIGHTSOURCE AT PHOLC.SE
DIMMING: NO, ON/OFF SWITCH
DIFFUSER: NO
CABLE: TEXTILE CABLE, BLACK, 300 CM
MOUNTING: CABLE TYPE
CLASS: CLASS II
IP: IP20
CERTIFICATION: CE

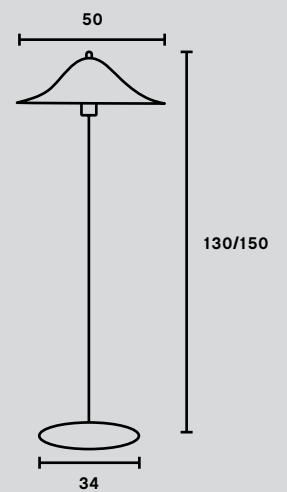

KANDINSKY 30 PENDANT



ITEM NO° 517 119
SMOKED GREY—BRASS

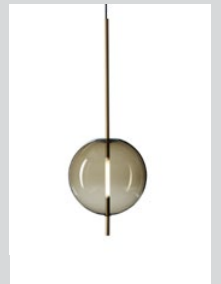

ITEM NO° 517 112
SMOKED BROWN—
BRASS

DESIGN: BROBERG & RIDDERSTRÅLE, 2019
CATEGORY: PENDANT
MATERIAL: GLASS & BRASS
CEILING CUP MATERIAL: METAL
MAX WATT: 1*5W
LIGHTSOURCE: LIGHTSOURCE INCLUDED
DIMMING: YES
DIFFUSER: NO
CABLE: TEXTILE CABLE, BLACK, 300 CM
MOUNTING: CEILING CUP, BLACK, TERMINAL BLOCK
CLASS: CLASS II
IP: IP20
CERTIFICATION: CE

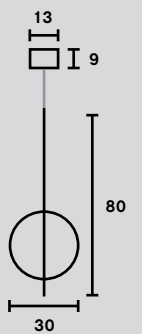

KANDINSKY 45 PENDANT



ITEM NO° 518 112
SMOKED BROWN—BRASS

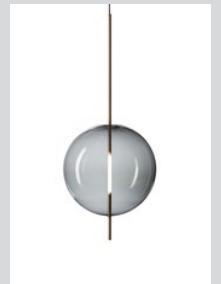

ITEM NO° 518 119
SMOKED GREY—
BRASS

DESIGN: BROBERG & RIDDERSTRÅLE, 2019
CATEGORY: PENDANT
MATERIAL: GLASS & BRASS
CEILING CUP MATERIAL: METAL
MAX WATT: 1*6W
LIGHTSOURCE: LIGHTSOURCE INCLUDED
DIMMING: YES
DIFFUSER: NO
CABLE: TEXTILE CABLE, BLACK, 300 CM
MOUNTING: CEILING CUP, BLACK, TERMINAL BLOCK
CLASS: CLASS II
IP: IP20
CERTIFICATION: CE

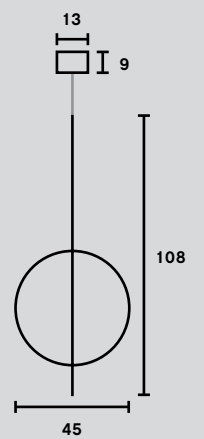

MOBIL 70 PENDANT



ITEM NO° 510 134
MATTE NICKEL

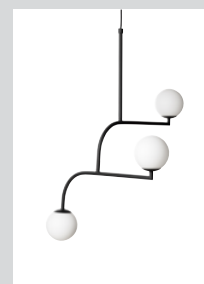

ITEM NO° 510 135
MATTE BLACK



ITEM NO° 510 138
BRUSHED BRASS

DESIGN: MONIKA MULDER, 2016
CATEGORY: PENDANT
MATERIAL: BRASS/METAL/NICKEL & OPAL GLASS
CEILING CUP MATERIAL: METAL
SOCKET: G9
MAX WATT: 3*20W
LIGHTSOURCE: SEE RECOMMENDED LIGHTSOURCE AT PHOLC.SE
DIMMING: DEPENDING ON LIGHTSOURCE
DIFFUSER: NO
CABLE: TEXTILE CABLE, WHITE ON NICKEL AND BRASS, BLACK ON BLACK, 300 CM
MOUNTING: CEILING CUP, MATCHING COLOUR AS SHADE, TERMINAL BLOCK
CLASS: CLASS I
IP: IP20
CERTIFICATION: CE

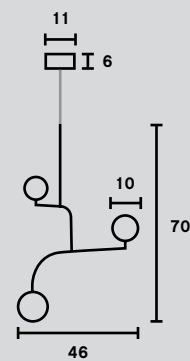

MOBIL 100 PENDANT

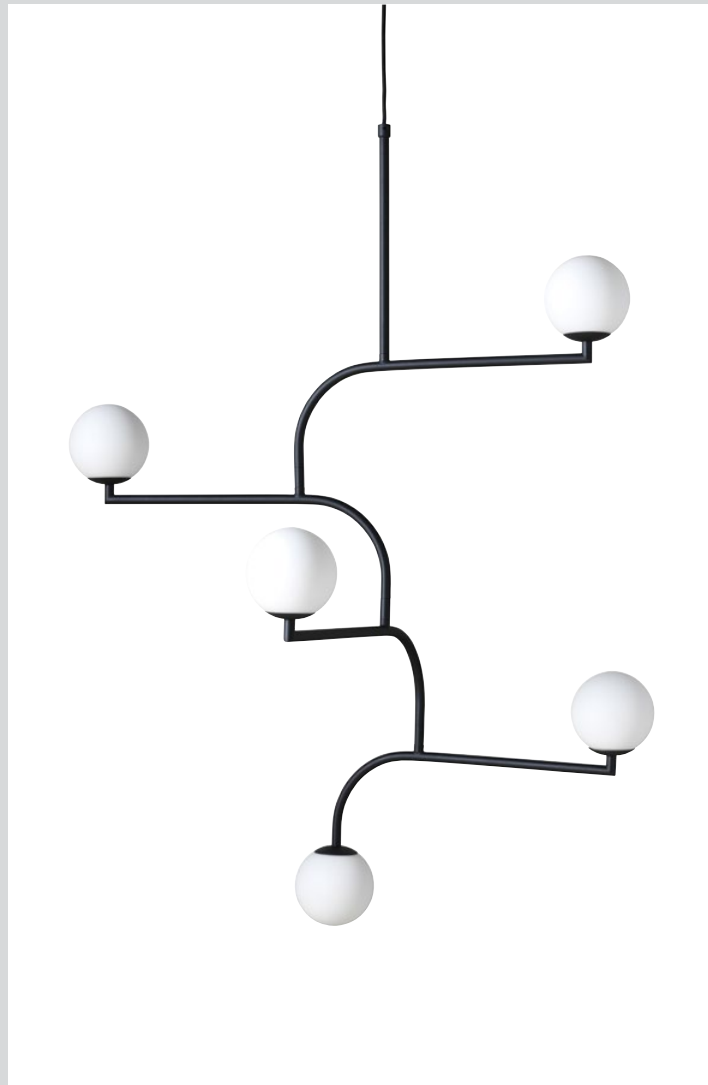

ITEM NO° 510 155
MATTE BLACK

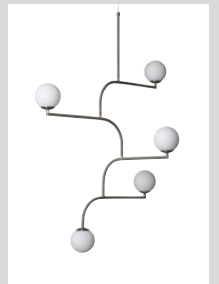

ITEM NO° 510 154
MATTE NICKEL



ITEM NO° 510 158
BRUSHED BRASS

DESIGN: MONIKA MULDER, 2016
CATEGORY: PENDANT
MATERIAL: BRASS/METAL/NICKEL & OPAL GLASS
CEILING CUP MATERIAL: METAL
SOCKET: G9
MAX WATT: 5*20W
LIGHTSOURCE: SEE RECOMMENDED LIGHTSOURCE AT PHOLC.SE
DIMMING: DEPENDING ON LIGHTSOURCE
DIFFUSER: NO
CABLE: TEXTILE CABLE, WHITE ON NICKEL AND BRASS, BLACK ON BLACK, 300 CM
MOUNTING: CEILING CUP, MATCHING COLOUR AS SHADE, TERMINAL BLOCK
CLASS: CLASS I
IP: IP20
CERTIFICATION: CE

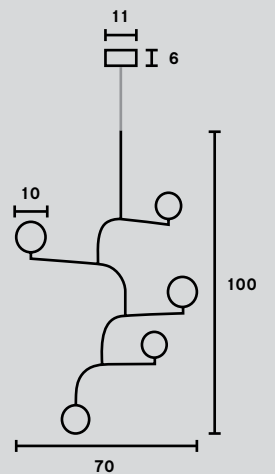

MOBIL TABLE

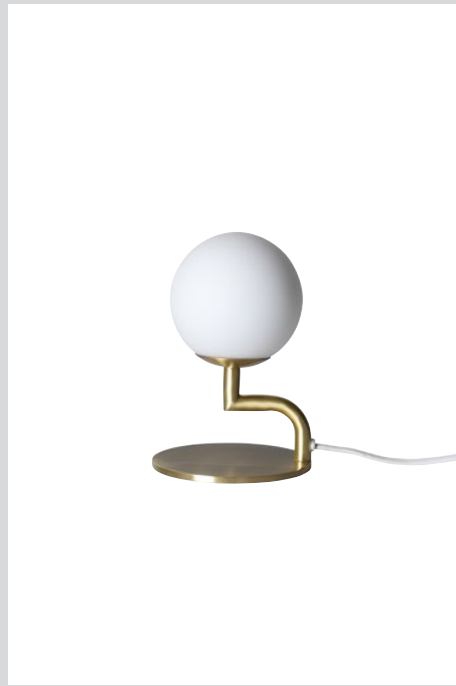

ITEM NO° 510 318
BRUSHED BRASS

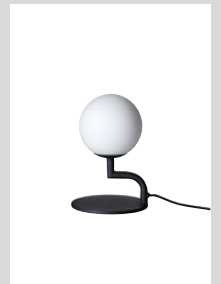

ITEM NO° 510 315
MATTE BLACK

DESIGN: MONIKA MULDER, 2016
CATEGORY: TABLE
MATERIAL: METAL/BRASS & OPAL GLASS
SOCKET: G9
MAX WATT: 1*20W
LIGHTSOURCE: SEE RECOMMENDED LIGHTSOURCE AT PHOLC.SE
DIMMING: YES
DIFFUSER: NO
CABLE: TEXTILE CABLE, WHITE ON BRASS, BLACK ON BLACK, 200 CM
MOUNTING: CABLE TYPE
CLASS: CLASS II
IP: IP20
CERTIFICATION: CE

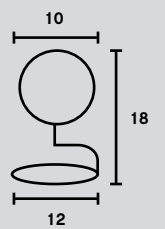

MOBIL 12 WALL

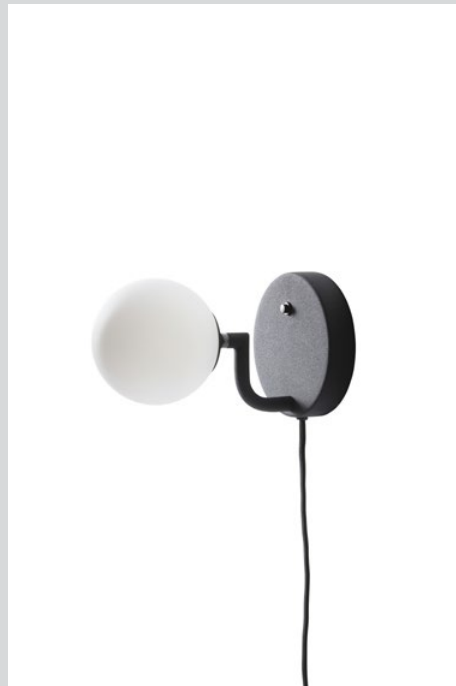

ITEM NO° 513 215
MATTE BLACK

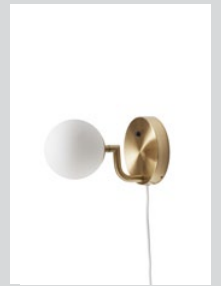

ITEM NO° 513 218
BRUSHED BRASS

DESIGN: MONIKA MULDER, 2016
CATEGORY: WALL
MATERIAL: METAL/BRASS & OPAL GLASS
SOCKET: G9
MAX WATT: 1*20W
LIGHTSOURCE: SEE RECOMMENDED LIGHTSOURCE AT PHOLC.SE
DIMMING: NO, ON/OFF SWITCH
DIFFUSER: NO
CABLE: TEXTILE CABLE, WHITE ON BRASS, BLACK ON BLACK, 200 CM
MOUNTING: CABLE TYPE & FIXED INSTALLATION
CLASS: CLASS II
IP: IP20
CERTIFICATION: CE

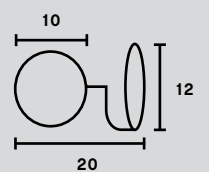

MOBIL 46 WALL

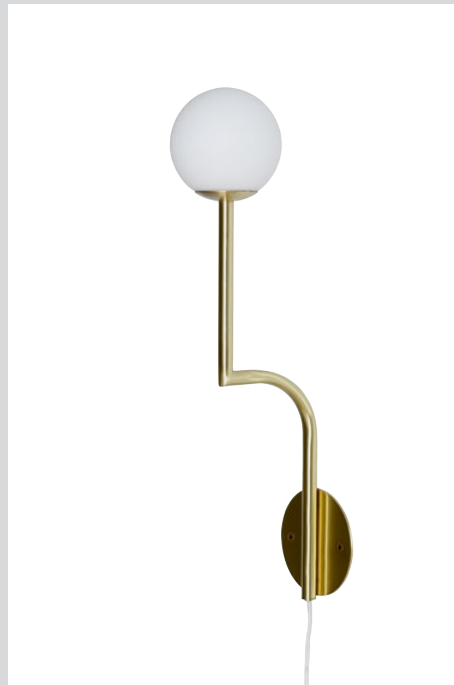

ITEM NO° 510 218
BRUSHED BRASS

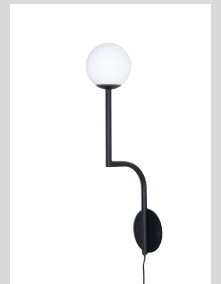

ITEM NO° 510 215
MATTE BLACK

DESIGN: MONIKA MULDER, 2016
CATEGORY: WALL
MATERIAL: BRASS/METAL/NICKEL & OPAL GLASS
CEILING CUP MATERIAL: METAL
SOCKET: G9
MAX WATT: 1*20W
LIGHTSOURCE: SEE RECOMMENDED LIGHTSOURCE AT PHOLC.SE
DIMMING: DEPENDING ON LIGHTSOURCE
DIFFUSER: NO
CABLE: TEXTILE CABLE, WHITE ON NICKEL AND BRASS, BLACK ON BLACK, 200 CM
MOUNTING: CEILING CUP, MATCHING COLOUR AS SHADE, TERMINAL BLOCK
CLASS: CLASS I
IP: IP20
CERTIFICATION: CE

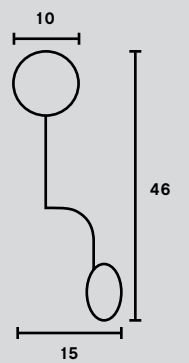

**MOBIL 46 WALL
(FIXED)**

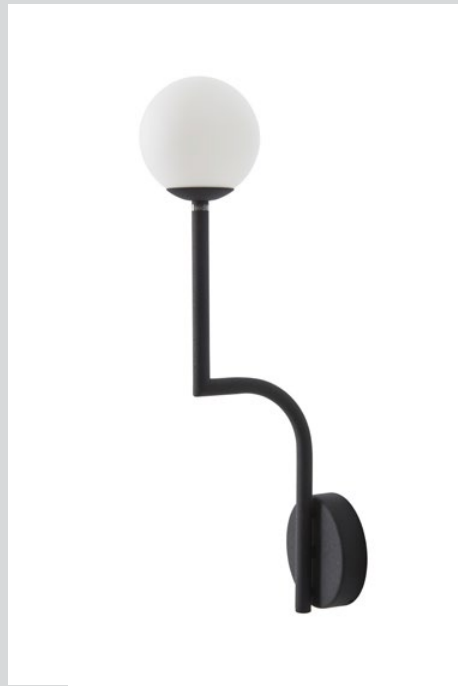

**ITEM NO° 512 215
MATTE BLACK**

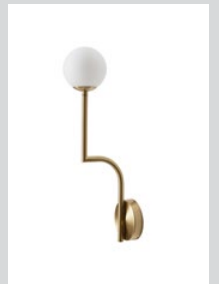

**ITEM NO° 512 218
BRUSHED BRASS**

DESIGN: MONIKA MULDER, 2016
CATEGORY: WALL
MATERIAL: METAL/BRASS & OPAL GLASS
SOCKET: G9
MAX WATT: 1*20W
LIGHTSOURCE: SEE RECOMMENDED LIGHTSOURCE AT PHOLC.SE
DIMMING: NO
DIFFUSER: NO
MOUNTING: FIXED INSTALLATION
CLASS: CLASS II
IP: IP20
CERTIFICATION: CE

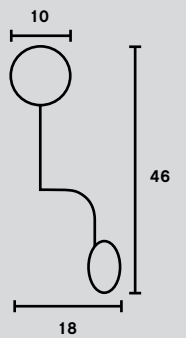

MOBIL 150 WALL

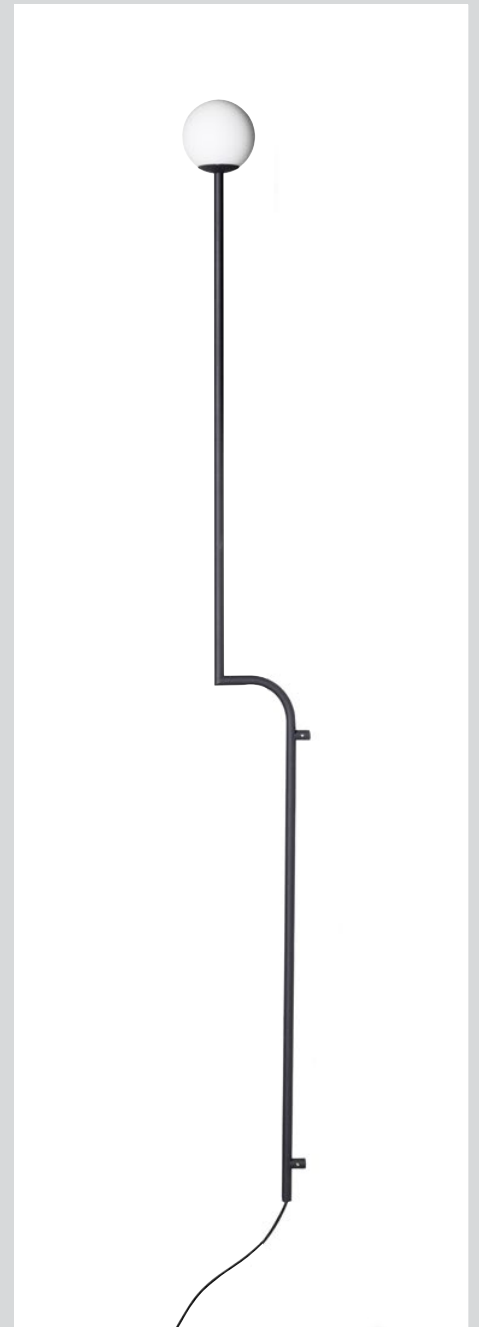

ITEM NO° 511 215
MATTE BLACK

DESIGN: MONIKA MULDER, 2017
CATEGORY: WALL
MATERIAL: METAL & OPAL GLASS
SOCKET: G9
MAX WATT: 1*20W
LIGHTSOURCE: SEE RECOMMENDED LIGHTSOURCE AT PHOLC.SE
DIMMING: YES
DIFFUSER: NO
CABLE: TEXTILE CABLE, BLACK, 200 CM
MOUNTING: CABLE TYPE
CLASS: CLASS II
IP: IP20
CERTIFICATION: CE

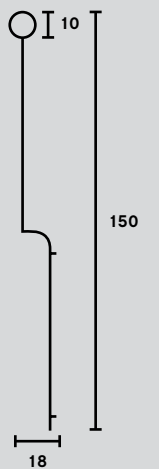

PEARLS 65 PENDANT



ITEM NO° 530 124
SHINY NICKEL



ITEM NO° 530 128
BRUSHED BRASS

DESIGN: MONIKA MULDER, 2017
CATEGORY: PENDANT
MATERIAL: BRASS/NICKEL & OPAL GLASS
CEILING CUP MATERIAL: METAL
SOCKET: G9
MAX WATT: 2*20W
LIGHTSOURCE: SEE RECOMMENDED LIGHTSOURCE AT PHOLC.SE
DIMMING: DEPENDING ON LIGHTSOURCE
DIFFUSER: NO
CABLE: TEXTILE CABLE, WHITE, 300 CM
MOUNTING: CEILING CUP, MATCHING COLOUR AS SHADE, TERMINAL BLOCK
CLASS: CLASS I
IP: IP20
CERTIFICATION: CE

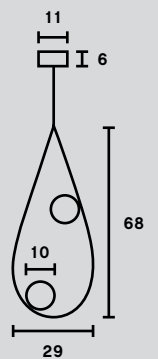

PEARLS 80 PENDANT



ITEM NO° 530 138
BRUSHED BRASS



ITEM NO° 530 134
SHINY NICKEL

DESIGN: MONIKA MULDER, 2017
CATEGORY: PENDANT
MATERIAL: BRASS/NICKEL & OPAL GLASS
CEILING CUP MATERIAL: METAL
SOCKET: G9
MAX WATT: 3*20W
LIGHTSOURCE: SEE RECOMMENDED LIGHTSOURCE AT PHOLC.SE
DIMMING: DEPENDING ON LIGHTSOURCE
DIFFUSER: NO
CABLE: TEXTILE CABLE, WHITE, 300 CM
MOUNTING: CEILING CUP, MATCHING COLOUR AS SHADE, TERMINAL BLOCK
CLASS: CLASS I
IP: IP20
CERTIFICATION: CE

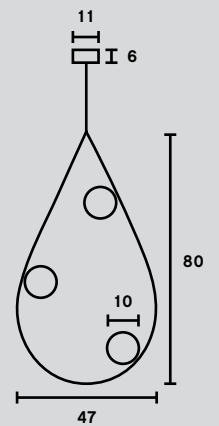

ROMB 36 TABLE



ITEM NO° 207 313
COTTON



ITEM NO° 207 318
CUMIN

DESIGN: BROBERG & RIDDERSTRÅLE, 2021
CATEGORY: TABLE
MATERIAL: ALUMINIUM
SOCKET: E27
MAX WATT: 1*12W
LIGHTSOURCE: LIGHTSOURCE INCLUDED
DIMMING: YES, CABLE VERSION
DIFFUSER: NO
CABLE: PVC CABLE, BLACK, 250 CM
MOUNTING: CABLE TYPE
CLASS: CLASS II
IP: IP20
CERTIFICATION: CE

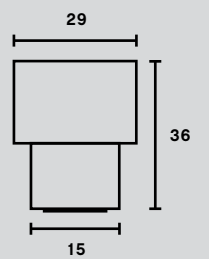

ROMB 48 TABLE

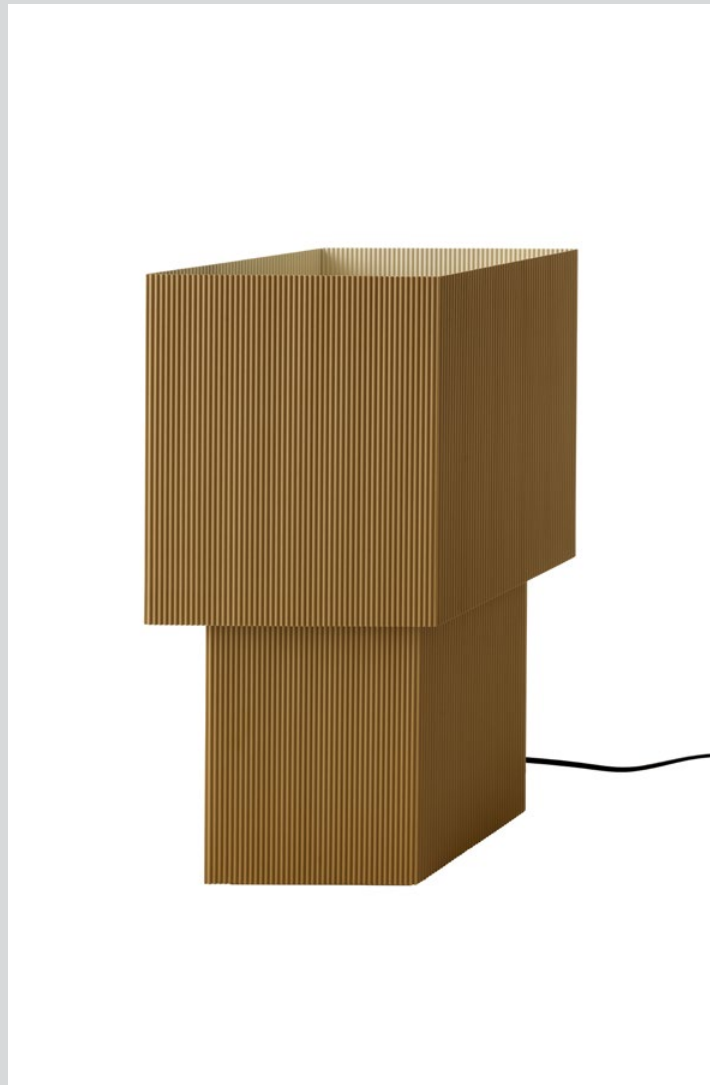

ITEM NO° 217 313
COTTON

ITEM NO° 217 318
CUMIN

DESIGN: BROBERG & RIDDERSTRÅLE, 2021
CATEGORY: TABLE
MATERIAL: ALUMINIUM
SOCKET: E27
MAX WATT: 1*12W
LIGHTSOURCE: LIGHTSOURCE INCLUDED
DIMMING: YES, CABLE VERSION
DIFFUSER: NO
CABLE: PVC CABLE, BLACK, 250 CM
MOUNTING: CABLE TYPE
CLASS: CLASS II
IP: IP20
CERTIFICATION: CE

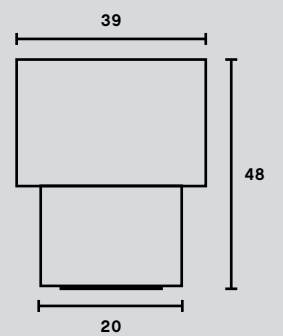

SPINN 39 PENDANT



ITEM NO° 502 112
NATURE

DESIGN: SABINA GRUBBESON, 2015
CATEGORY: PENDANT
MATERIAL: WAXED PAPER CORD
CEILING CUP MATERIAL: METAL
SOCKET: E27
MAX WATT: 1*42W
LIGHTSOURCE: SEE RECOMMENDED LIGHTSOURCE AT PHOLC.SE
DIMMING: DEPENDING ON LIGHTSOURCE
DIFFUSER: NO
CABLE: TEXTILE & PVC CABLE, BLACK, 300 CM (NATURE), 150 CM (BLUE)
MOUNTING: CEILING CUP, MATCHING COLOUR AS SHADE, TERMINAL BLOCK
CLASS: CLASS I
IP: IP20
CERTIFICATION: CE

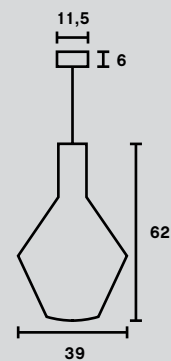

SPINN 39 FLOOR

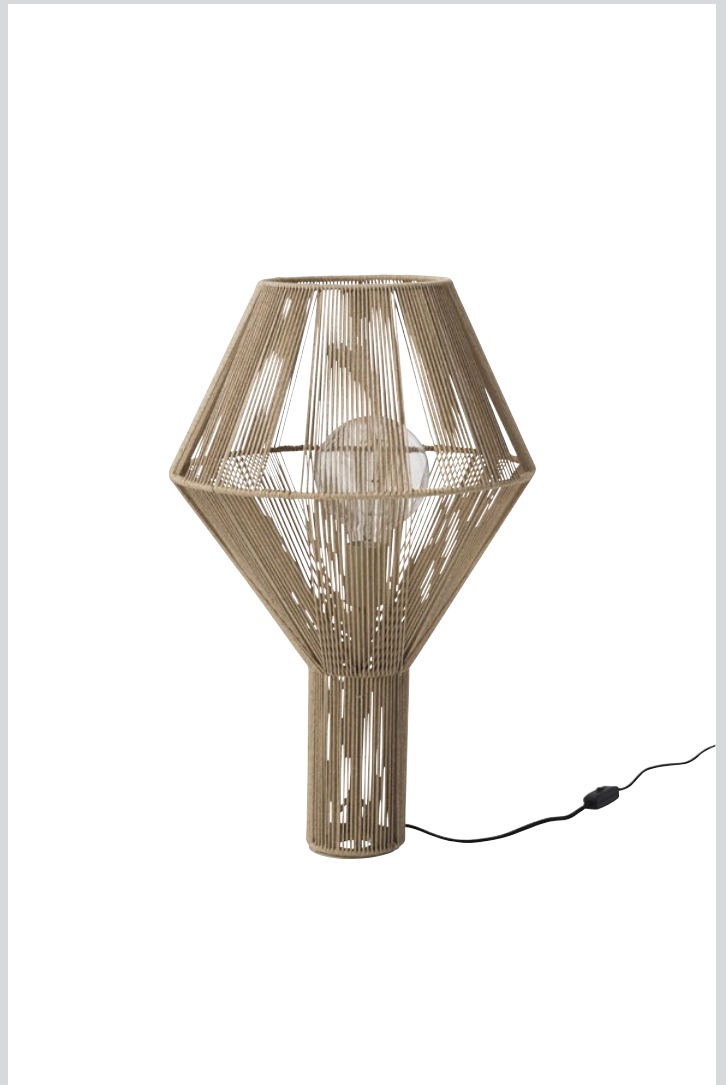

ITEM NO° 502 412
NATURE

DESIGN: SABINA GRUBBESON, 2015
CATEGORY: FLOOR
MATERIAL: WAXED PAPER CORD
SOCKET: E27
MAX WATT: 1*42W
LIGHTSOURCE: SEE RECOMMENDED LIGHTSOURCE AT PHOLC.SE
DIMMING: YES
DIFFUSER: NO
CABLE: TEXTILE & PVC CABLE, BLACK, 400 CM
MOUNTING: CABLE TYPE
CLASS: CLASS II
IP: IP20
CERTIFICATION: CE

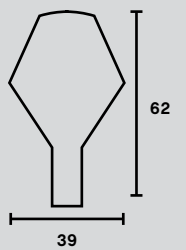

WWW. PHOLC. SE

IMAGES

FRONT COVER
ROMB 48 TABLE
ITEM NO° 217 313 COTTON

PAGE 01
ROMB 36 TABLE
ITEM NO° 207 318 CUMIN
ROMB 48 TABLE
ITEM NO° 217 318 CUMIN

PAGE 08
ROMB 48 TABLE
ITEM NO° 217 313 COTTON
ROMB 48 TABLE
ITEM NO° 217 318 CUMIN

BACK COVER
ROMB 48 TABLE
ITEM NO° 217 313 COTTON
ROMB 36 TABLE
ITEM NO° 207 318 CUMIN
ROMB 48 TABLE
ITEM NO° 217 318 CUMIN

IMAGE CREDITS

PAGE 28
© TOG (THE OFFICE GROUP)
DOUGLAS HOUSE WORK SPACE

PAGE 29
© TOG (THE OFFICE GROUP)
SUMMIT HOUSE WORK SPACE
PHOTO BY MICHAEL SINCLAIR

PHOLC CATALOGUE EDITION 2021

ART DIRECTION & DESIGN
NOTE

STYLING
SOFIE BRÜNNER

PHOTOGRAPHY
CARL ANDER
CARL JOHAN ENGBERG
ENOK HOLSEGAARD
KIMME PERSSON

PROFILE AND COPYEDITING
SARAH TROUNCE

PRODUCED BY
ELLINGTON PRINT & PRODUCTION

REPRO
JK MORRIS PRODUCTION

PHOLC STOCKHOLM © 2021
INFO@PHOLC.SE

WWW.PHOLC.SE

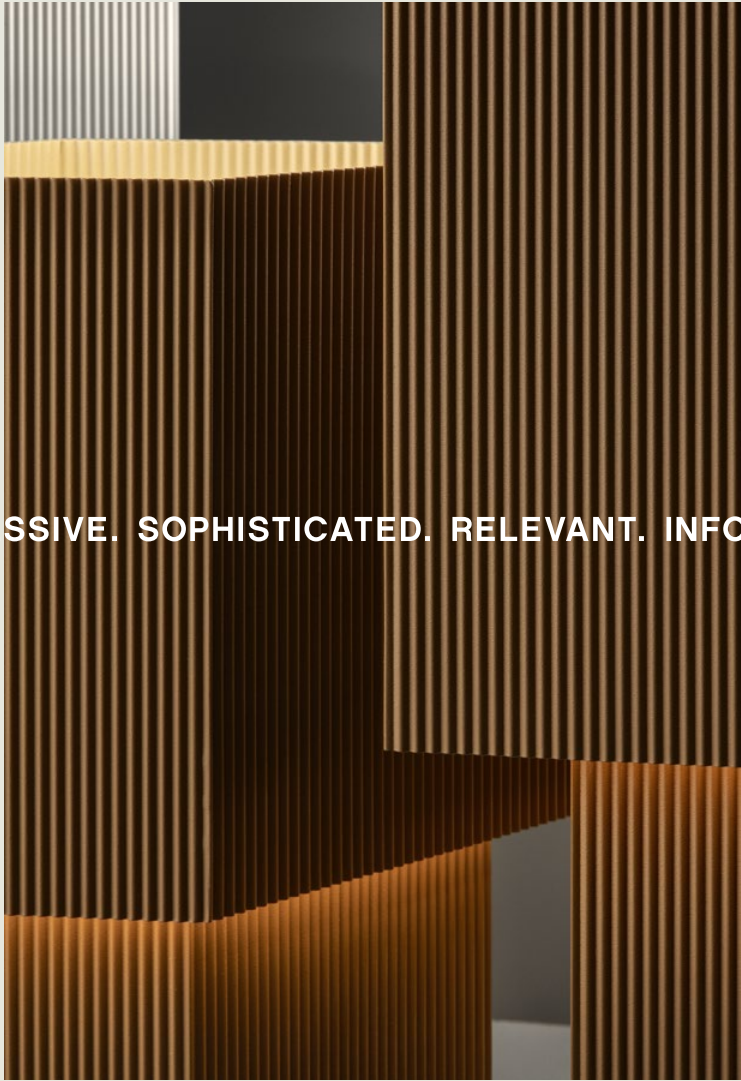

EXPRESSIVE. SOPHISTICATED. RELEVANT. INFORMED.

pholc